

CIVIL ENGINEERING

Paper – I

Time Allowed : Three Hours

Maximum Marks : 200

Question Paper Specific Instructions

Please read each of the following instructions carefully before attempting questions :

There are **EIGHT** questions in all, out of which **FIVE** are to be attempted.

Questions no. 1 and 5 are compulsory. Out of the remaining **SIX** questions, **THREE** are to be attempted selecting at least **ONE** question from each of the two Sections A and B.

Attempts of questions shall be counted in sequential order. Unless struck off, attempt of a question shall be counted even if attempted partly. Any page or portion of the page left blank in the Question-cum-Answer Booklet must be clearly struck off.

All questions carry equal marks. The number of marks carried by a question/part is indicated against it.

Answers must be written in **ENGLISH** only.

Unless otherwise mentioned, symbols and notations have their usual standard meanings.

Assume suitable data, if necessary, and indicate the same clearly.

Neat sketches may be drawn, wherever required.

SECTION A

- Q1. (a) Find the support reactions of the beam shown in the figure. The beam has an internal hinge at C.

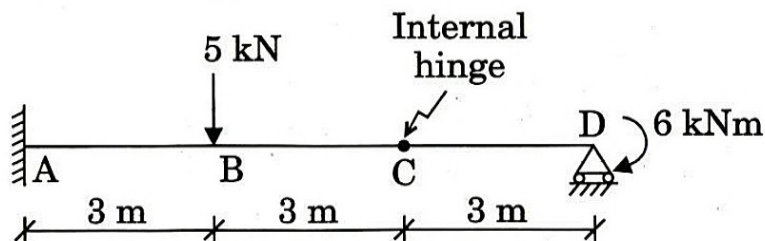

- (b) Determine the static indeterminacies of the following structures. Answers must be supported by calculations or brief explanations.

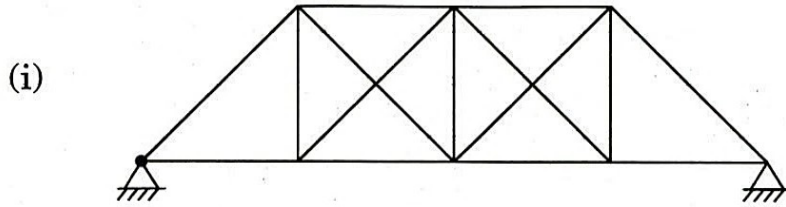

4

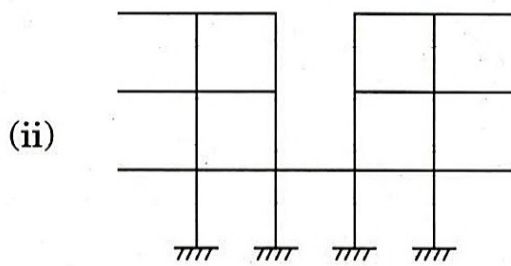

4

- (c) A right-angled rigid pipe is fixed to the wall at A and is additionally supported through the cable CD as shown in the figure. Determine the magnitudes of the moments about the x, y and z axes, if the tensile force applied to the cable is 3 kN.

8

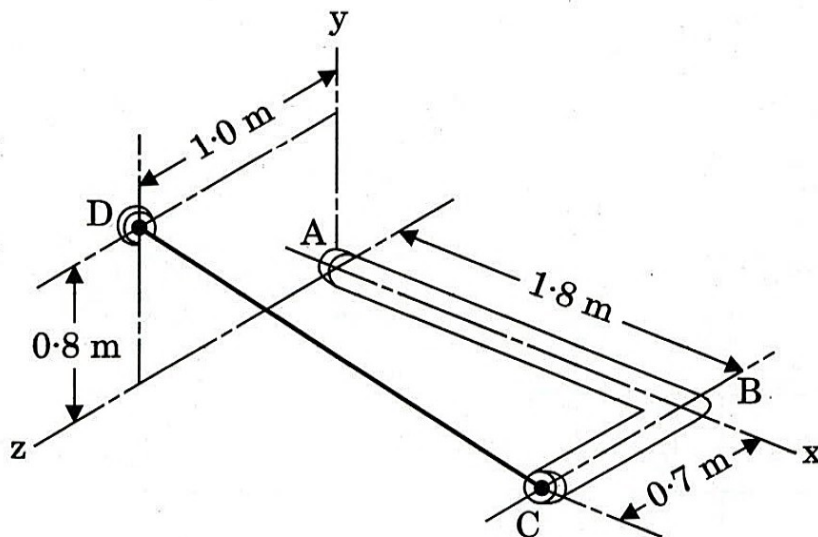

- (d) Two ISMC 350 channel sections are placed back-to-back to form a built-up section for the column as shown in the figure below. What will be the value of minimum spacing 'S' so that it will carry maximum compressive load ?

Assume properties of ISMC 350 as follows :

$$C/S \text{ area } (A) = 5366 \text{ mm}^2$$

$$C_{YY} = 24.4 \text{ mm}$$

$$I_{ZZ} = 10008 \text{ cm}^4$$

$$I_{YY} = 430.6 \text{ cm}^4$$

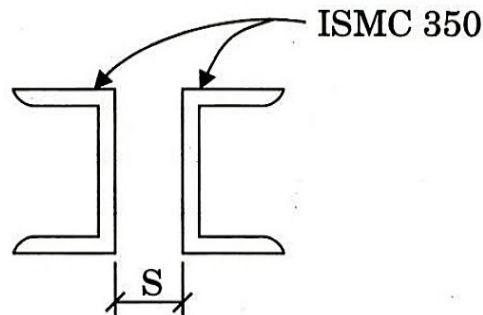

- (e) A simply supported beam of 5 m length is carrying a uniformly distributed factored load of 100 N/mm. The width and effective depth of the beam are 300 mm and 400 mm respectively. The steels at the tension and compression sides of the section consist of 3 – 16 ϕ and 2 – 12 ϕ respectively which are continued all throughout. Design vertical stirrups for the section near support, if Fe 415 grade of steel and M 20 grade of concrete are used. Use 10 mm diameter two-legged stirrups. Use the following table for design purpose :

Percentage of tensile steel (p_t) versus Permissible shear stress (τ_c) in N/mm^2 for M 20 concrete

p_t	0.4	0.8	1.2	1.6	2.0	2.4	2.8	3.0
τ_c	0.44	0.57	0.66	0.73	0.79	0.82	0.82	0.82

- Q2.** (a) A three-hinged parabolic arch of total span 30 m has its two end supports at 4 m and 16 m below the crown respectively. The arch carries two concentrated loads, each of 60 kN in the middle of each portion of the arch on both sides of the crown as shown in the figure. Determine the horizontal thrust and vertical components of the reactions at supports. Also determine the bending moments acting under the concentrated loads.

10

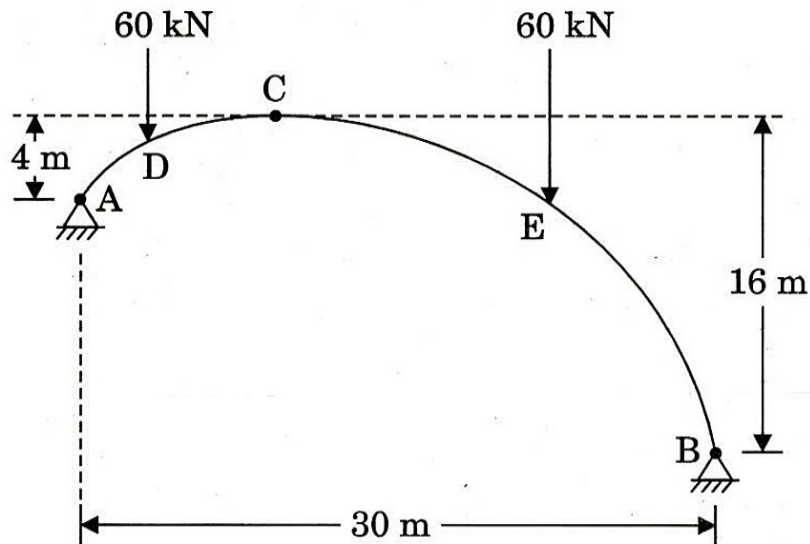

- (b) Draw the bending moment and shear force diagrams of the following beam as shown in the figure. The beam has an internal hinge at D.

15

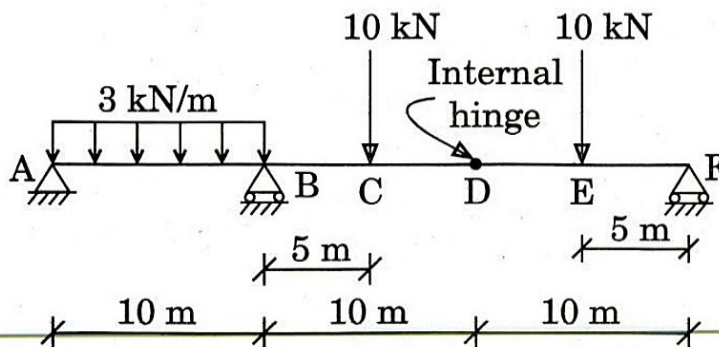

(c) A circular aluminium shaft of dimensions shown in the figure is subjected to two torques, $T_1 = 1500 \text{ N-m}$ and $T_2 = 200 \text{ N-m}$ as shown. The left end of the shaft is completely fixed. Determine

- (i) the angle of twist of the shaft at the right end,
- (ii) the percentage change in the angle of twist if a concentric hole of diameter 40 mm and length 400 mm is drilled through the shaft, starting from the fixed end (indicated by dotted lines into the figure).

The shear modulus of aluminium can be taken as $70 \times 10^9 \text{ N/m}^2$.

15

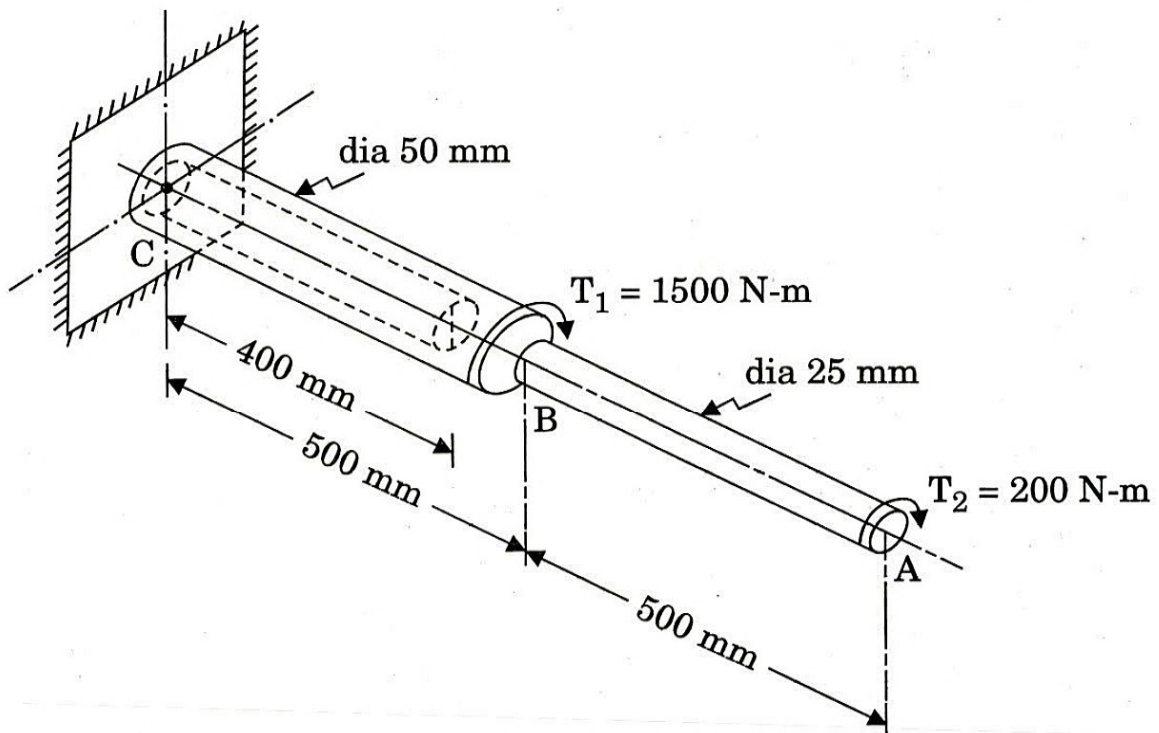

Q3. (a) An aluminium square bar having the cross-section $50 \text{ mm} \times 50 \text{ mm}$ and length 3 metres is fixed between two rigid supports as shown in the figure. Two loads, 15 kN and 30 kN are applied concentrically to the rod through collars as shown. Determine the stress developed at the right end of the bar. Young's modulus of aluminium is $70 \times 10^9 \text{ N/m}^2$.

10

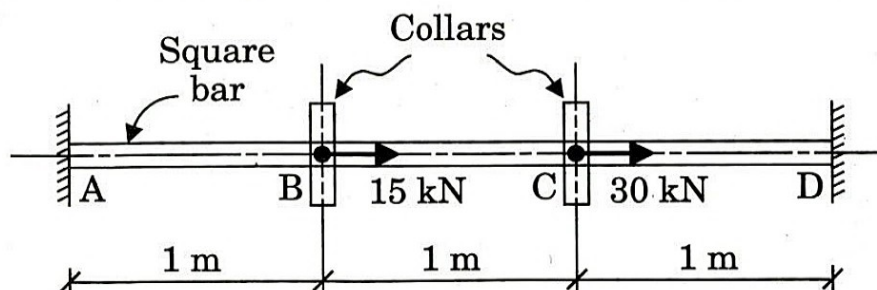

- (b) A steel beam having cross-section of an 'I' with overall depth 300 mm and flange width 150 mm is simply supported at both ends. The thickness of the flange, as well as the web is 20 mm for each. The beam needs to carry a concentrated load of 50 kN at its mid span. If the permissible bending stress is to be limited to 120 N/mm^2 , determine
- the maximum possible length of the beam,
 - the depth of an equivalent rectangular section, with the width fixed to be 100 mm. Also, determine the percentage increase in weight of the beam as compared to the beam with 'I' section.

10

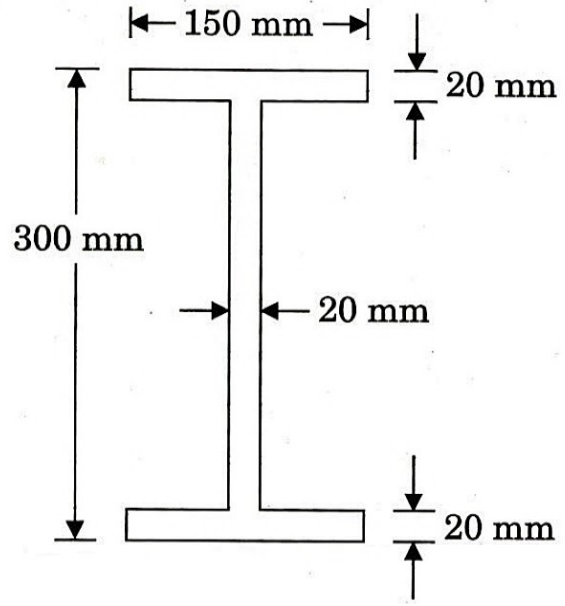

- (c) A tie member of a roof truss of ISA $90 \times 90 \times 10$ is connected to a 12 mm thick gusset plate by 6 mm size fillet weld. If the weld is to be done in three sides as shown in the figure below, find the length of the weld in upper (x) and lower (y) sides.

Assume Fe 410 grade steel is used.

Partial safety factors, $\gamma_{m0} = 1.1$ and $\gamma_{mw} = 1.25$.

For ISA $90 \times 90 \times 10$, assume C/S area = 1703 mm^2 and $C_z = 25.9 \text{ mm}$.

10

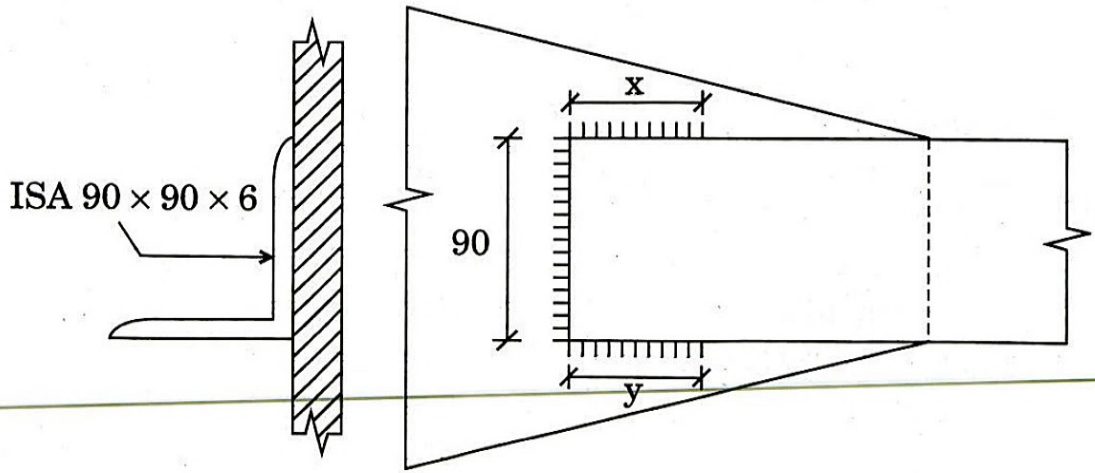

- (d) A prestressed concrete pile of 300 mm square, contains 50 pretensioned wires, each of 3 mm diameter, uniformly distributed over the section. The wires are initially tensioned on the prestressing bed with a total force of 400 kN. Calculate the final stress in concrete and the percentage loss of stress in steel after all losses, given the following data :

$$E_s = 210 \text{ kN/mm}^2$$

$$E_c = 32 \text{ kN/mm}^2$$

Shortening due to creep = 35×10^{-6} mm/mm per N/mm² of stress

Total shrinkage = 250×10^{-6} per unit length

Relaxation of steel stress = 6% of initial stress.

10

- Q4.** (a) A simply supported steel joist of 5 m effective length is laterally supported throughout. It carries a uniformly distributed load. The cross-section of the joist is given below. Determine the factored distributed load the joist can carry. Assume steel of grade Fe 410.

Assume factored design shear force will not exceed 0.6 times the design shear strength of the cross-section. Shear buckling check is not required.

$$\gamma_{m0} = 1.1, \beta_b = 1.0.$$

Neglect self-weight of the beam.

20

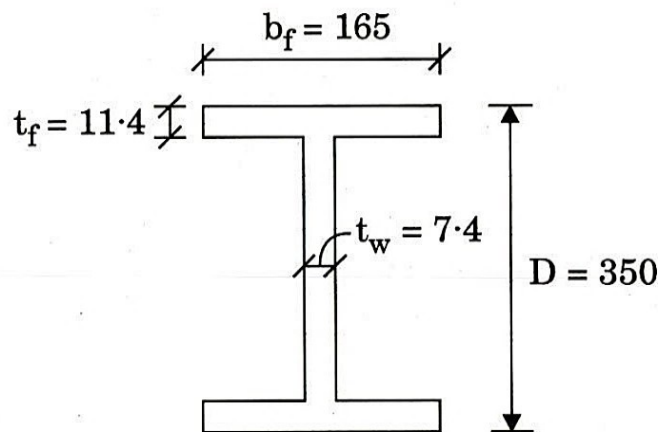

Built-up I-section

(All dimensions are in mm)

- (b) Design an axially loaded tied column of size 400 mm \times 400 mm with an unsupported length of 3 m. The compressive load on the column due to dead load is 800 kN and imposed load is 500 kN. The effective length of the column is 2.5 m. Diameters of longitudinal and transverse reinforcements are 20 mm and 10 mm respectively. Use Fe 415 for longitudinal reinforcement and Fe 250 for transverse reinforcement.

Grade of concrete is M 25.

20

SECTION B

- Q5. (a) A 3d flow field is given by

$$\vec{V} = (2x^2 + 3y) \mathbf{i} + (-2xy + 3y^2 + 3zy) \mathbf{j} + \left(-\frac{3}{2}z^2 + 2xz - 9y^2z\right) \mathbf{k}.$$

Determine the acceleration at (1, 1, 1).

8

- (b) The loss of head from the entrance to the throat of a 250 mm × 125 mm venturimeter is 1/8 times the velocity head at throat. Take the deflection of water mercury manometer as 101.6 mm. Compute the discharge.

8

- (c) A proposed model of a river stretch of 10 km is to have a horizontal scale of $\frac{1}{200}$ and a vertical scale of $\frac{1}{50}$. If the normal discharge, width and depth of the river are 120 m³/s, 80 m and 1.8 m respectively, estimate the corresponding model quantities.

8

- (d) An unsupported cut is shown in the figure below :

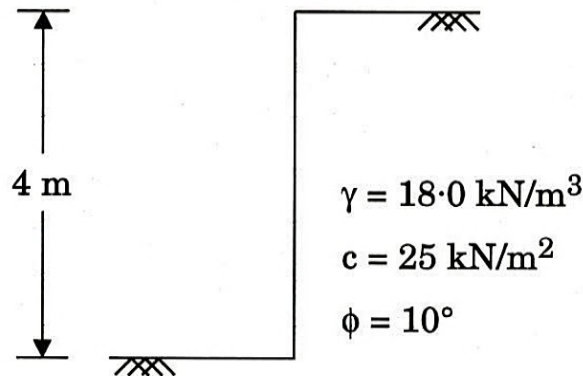

Determine (i) the lateral stress at top and bottom of the cut, (ii) the maximum depth of potential tension crack, and (iii) the maximum unsupported excavation.

8

- (e) The soil fill for a road embankment is to be compacted in place to a void ratio of 0.7. If the void ratio of the borrow pit soil is 1.2, how many cubic metres of compacted fill can be placed in the embankment per 1000 cubic metres of borrow material? If no water is either added or lost during the placement of the fill, what would be the change in degree of saturation of the soil?

8

- Q6.** (a) 300 litres/second of water is flowing in a pipe having a diameter of 250 mm. If the pipe is bent by 135° as shown in the figure below, find the magnitude and direction of the resultant force on the bend. Pressure acting at sections (1) and (2) is 500 kN/m^2 ($P_1 = P_2 = 500 \text{ kN/m}^2$). Assume steady flow. $\rho = 1000 \text{ kg/m}^3$, neglect self-weight of water in the bend.

15

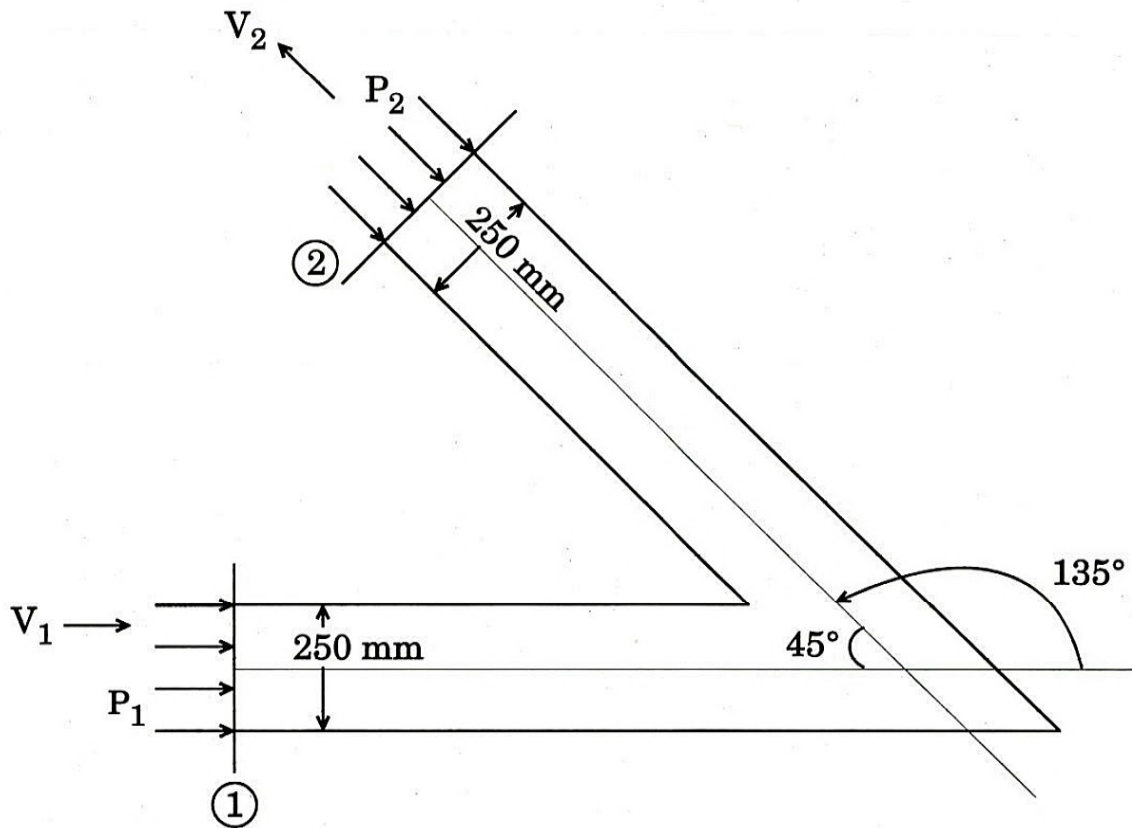

- (b) Two pipes each of length 'L' and diameters ' d_1 ' and ' d_2 ' are arranged in parallel, the loss of head when a total quantity of water Q flows through them is h_{LP} . If the pipes are arranged in series and the same quantity of water Q flows through them, the loss of head is h_{LS} . If $d_1 = 3d_2$ and $f_1 = 2f_2$, find the ratio of h_{LP} to h_{LS} . Neglect minor losses.

15

- (c) A hydraulic jump occurs in a horizontal right-angled triangular channel. If the sequent depths in this channel are 0.5 m and 1.5 m respectively, estimate :

10

- (i) The flow rate
- (ii) Froude numbers at the starting and end of the jump
- (iii) Energy loss in the hydraulic jump

- Q7. (a) For the soil profile given below, determine the total and effective stresses at point 'A'. What will be the total, neutral and effective stresses at point 'A', if the ground water table rises to the ground surface? Will there be any change in effective stress at point 'A', if the water table rises 2 m above the ground surface? Answer with justification.

15

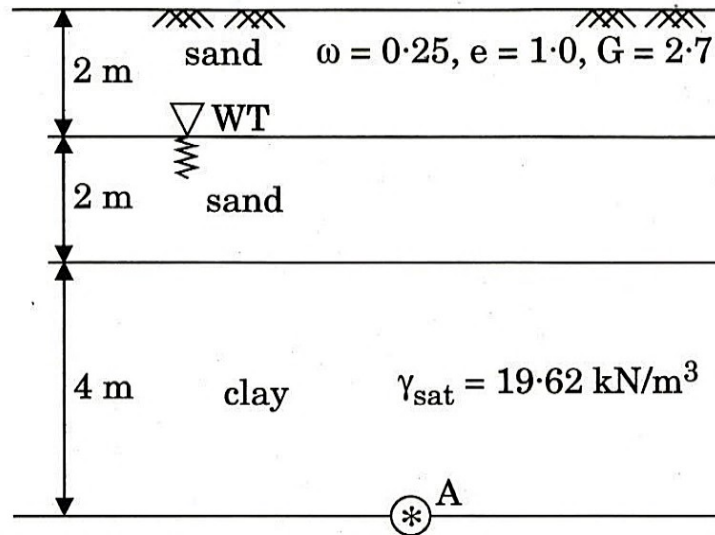

- (b) A 12.0 m thick clay layer with coefficient of consolidation, $c_v = 8.0 \times 10^{-8} \text{ m}^2/\text{s}$ exists at a site as shown in the figure below. If the average vertical stress increase in the clay layer due to the structural load is 100 kPa, determine the time required to settle the clay layer by 250 mm. Assume the clay layer is normally consolidated and the total unit weight of sand above the water table is same as it is below the water table.

15

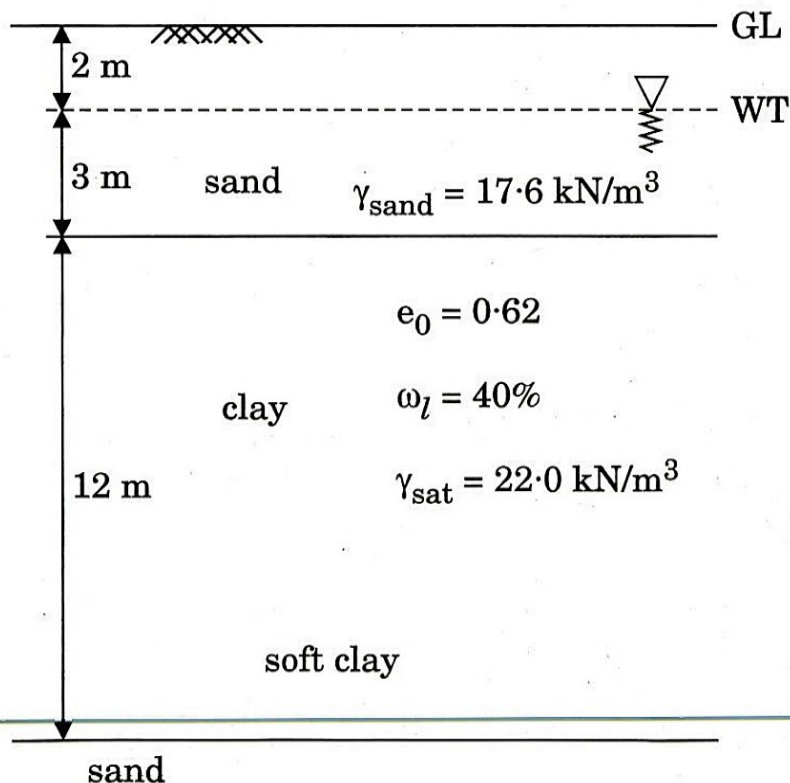

- (c) When do we prefer deep foundation ? Explain the method to determine the vertical load carrying capacity of single pile in sand and clay. 10

- Q8. (a) (i) Define boundary layer thickness, displacement thickness, momentum thickness. 15
- (ii) For the velocity profile $\frac{u}{U_\infty} = \left(\frac{y}{\delta}\right)^{1/7}$, calculate the ratio of displacement thickness and momentum thickness.

- (b) A dam turbine has runner diameter of 5.0 m. The turbine is rated at 11 MW under the head of 100 m at 120 rpm. The power efficiency is 88%.

- (i) Give the definition for specific speed of the turbine.
- (ii) Compute the specific speed.
- (iii) Compute the discharge required to run the turbine.
- (iv) Determine the torque developed by the turbine runner.

Specific weight of water = 9810 N/m³. 10

- (c) A square footing with side 1.5 m is to be constructed at 1.2 m below the ground surface. The subsoil consists of uniform deposit of dense soil having angle of internal friction, $\phi = 25^\circ$ and cohesion, $c = 50 \text{ kN/m}^2$. The ground water is at a great depth and its effect can be ignored. Determine the safe bearing capacity of the footing with a factor of safety = 3.0. If the water table rises to the base of the footing, what will be the safe bearing capacity of the footing ? Given for $\phi = 25^\circ$, $N_c = 21$, $N_q = 10$ and $N_\gamma = 6$, and dry and saturated unit weight of soil, $\gamma_d = 16 \text{ kN/m}^3$ and $\gamma_{\text{sat}} = 18 \text{ kN/m}^3$, respectively. 15

